

# Applying Design Thinking to Teach Physics and Mathematics: A Case Study on Building a Parachute and Analyzing Its Properties

Anna Koumara<sup>1,2,\*</sup>, Michael Bakaloglou<sup>2</sup> & Hariton M. Polatoglou<sup>1</sup>

<sup>1</sup>School of Physics, Aristotle University of Thessaloniki, Thessaloniki, Greece

<sup>2</sup>STEM Education Hellas, Greece

\*Correspondence: School of Physics, Aristotle University of Thessaloniki, University Campus, 54124, Thessaloniki, Greece. E-mail: anniekmr@gmail.com

Received: September 22, 2024

Accepted: October 28, 2024

Online Published: November 29, 2024

doi:10.5430/wje.v14n4p22

URL: <https://doi.org/10.5430/wje.v14n4p22>

## Abstract

Eleven high school students participated in a one-week STEM summer camp focused on designing and building parachutes to deliver fragile objects safely. Using the Engineering Design Process (EDP) as a framework, students explored how canopy size affects performance. They applied physics concepts such as terminal velocity, forces, and acceleration, alongside mathematical skills like diagram interpretation. The program incorporated innovative technologies, including 3D design and printing tools and the BBC micro:bit microcontroller. Students followed the EDP steps—designing, building, testing, and refining prototypes—while also discussing the nature of science and distinguishing it from engineering practices. The camp successfully met its objectives: students enhanced their understanding of physics concepts, grasped key aspects of the nature of science, and demonstrated the ability to follow the EDP. They designed and built two parachutes, collected and analyzed data from test falls, and drew meaningful conclusions. This study highlights the potential of integrating engineering, physics, mathematics, and the nature of science into STEM education. The findings suggest that guided use of the EDP and modern technologies can improve students' scientific knowledge and problem-solving skills, fostering a deeper engagement with STEM concepts.

**Keywords:** STEM project, EDP, physics concepts

## 1. Introduction

In recent years, STEM education has garnered increasing attention and has been embedded in the curricula of numerous countries (NGSS, 2013; English & King, 2015; Roehrig et al., 2021). Integrated STEM, which emphasizes the simultaneous application of Science, Technology, Engineering, and Mathematics, is widely regarded as an effective instructional approach (Roehrig et al., 2015; Kelley & Knowles, 2016; English, 2022). While debates persist regarding the number of disciplines that should be integrated into individual projects (Roehrig et al., 2021; Anderson, 2020; Millar, 2020), the core principles of STEM education remain its real-world relevance (Kelley & Knowles, 2016), student-centered learning environments (Millar, 2020), and the development of critical skills (Han et al., 2022; Roehrig et al., 2021).

In science and mathematics education, teachers typically possess specialized degrees (Roehrig et al., 2012). However, technology often serves dual roles as either a standalone subject requiring curriculum updates to align with contemporary demands (Reinsfield, 2020) or as a teaching tool in the form of educational technology (Januszewski & Molenda, 2013). Engineering, though increasingly emphasized in educational reform (Ali & Tse, 2023; Bybee, 2011), raises the question of who should teach it. While most teachers lack formal training in engineering principles, research indicates that effective professional development (PD) programs can equip teachers to integrate engineering into their teaching, with effectiveness improving through experience (Roehrig et al., 2021; Ampartzaki et al., 2022).

Engineering, defined as the process of designing and creating artifacts to improve human well-being (Kroes, 2012), plays a critical role in bridging scientific and mathematical knowledge through real-world problem-solving (Roehrig et al., 2021; Zhou et al., 2020). It also helps students appreciate the societal implications of engineering (Pleasant,

2023). While science focuses on understanding natural phenomena, engineering applies this knowledge to develop solutions for human prosperity (Barak et al., 2022). Understanding these distinctions is crucial for STEM education (Antink-Meyer & Brown, 2019; Bybee, 2011).

Parachutes provide a compelling context for integrated STEM projects due to their simplicity and relevance to everyday life. Their principles, which involve weight (a constant force) and drag (a variable force that leads to terminal velocity), align with middle school science concepts (Gluck, 2003; Langbeheim, 2015). Furthermore, parachutes have diverse applications, from recreational activities to space exploration.

The primary objectives of this study are to engage students in an integrated STEM project using advanced educational technologies and to enhance their understanding of science and mathematics. Additionally, the project aims to address epistemological issues, helping students differentiate between the methodologies and goals of science and engineering.

## 2. Theoretical Background

This study explores the teaching of physics and mathematics concepts and their integration through a STEM project, employing the Engineering Design Process (EDP) as the central methodology. The EDP, a systematic approach engineers use to address problems, involves proposing solutions, designing prototypes, testing, and revising (Hales & Gooch, 2004). Although variations of the EDP exist, key phases consistently include problem identification, solution generation and creation, and iterative improvement (Arik & Topcu, 2023; Lin et al., 2021). Prominent models, such as those by Atman et al. (2007) and Hynes (2012), outline detailed stages that guide students in applying engineering skills, including problem definition, brainstorming, and evaluation.

Research highlights the EDP's value in teacher training, where it enhances educators' self-efficacy, confidence, and soft skills (Arik & Topcu, 2023; Lin et al., 2021; Yesilyurt et al., 2021; Shahali et al., 2017) while also serving as an effective assessment tool (Shahat et al., 2023; Wind et al., 2019). It bridges STEM fields, enabling students to apply scientific inquiry and mathematical analysis to real-world problems (Kelley & Knowles, 2016). EDP-based learning has shown to increase student interest, confidence, and project achievement (Wind et al., 2019), although countries without formal engineering curricula face challenges in integrating it into classrooms (Sulaeman et al., 2021). This issue was mitigated in the present work by implementing the project in a STEM summer camp, an informal learning environment that fosters exploration beyond rigid school curricula (Roberts et al., 2018). Camps have a positive influence on students' views on STEM and motivate them to be engaged in STEM fields (Faber et al., 2020), in formal STEM learning environments and have positive impacts on their STEM self-efficacy, motivation and experience, and has the potential to support their pursue of a STEM career in the future (Gossen & Ivey, 2023; Roberts et al., 2018). Also, it can help students understand concepts and their ability to recall information (Popovic & Lederman, 2015).

Students in the camp used contemporary technologies, such as physical computing and 3D design and printing. Physical computing involves using devices like the BBC micro:bit to collect and process data from the physical world, promoting interactive learning (Grillenberger, 2023). The related literature is new but rich in teaching science concepts using proper software and microcontrollers, like Arduino, Raspberry Pie, or BBC Micro:bit, (i.e., Wahyuini et al., 2021; Teiermayer, 2019; Kinchin, 2018; Kelley & Knowles, 2016). The micro:bit was chosen for its user-friendly, open-source programming environment and affordability, enabling students to focus on project aspects beyond coding (Wahyuini et al., 2021). Similarly, 3D printing, combined with CAD software, fosters creativity, problem-solving, and iterative learning (Novak, 2022; Dickson et al., 2021; Assante et al., 2020;). Failures during the design and printing processes were leveraged as opportunities for reflection, motivation, and skill development (Pearson & Dude, 2022; Celik & Ozdemir, 2019). 3D printers' cost is getting lower, educational maker spaces can afford getting one or even more, but the emerging problem is the teacher training to support them (Thyssen & Meier, 2023).

The project also emphasized the Nature of Science (NOS). Regarding science teaching, in contemporary science curricula, teaching refers to the inclusion of a) content knowledge, b) inquiry methods, and c) the understanding of how science works, meaning the nature of science (NOS) (Bell, 2008 pp. 13-18). Even though there is no agreement among researchers on the characteristics of the nature of science, they all agree that it is important to integrate it into science teaching, to activate students, encourage them to work in science, understand the limitations of science, and understand the difference between science and pseudoscience (Lederman et al., 2014b; McComas, 2020, p.67-111). There are various working models on NOS, therefore we decided to use the suggestion from the Lederman team

(Lederman et al, 2014a & 2014b), that separate nature of scientific knowledge (NOSK) and nature of scientific inquiry (NOSI). The aspects of each are shown in Tables 1 and 2, respectively.

By combining EDP with cutting-edge technology and NOS principles, this work demonstrates an innovative approach to STEM education, equipping students with interdisciplinary skills, fostering deeper engagement, and addressing challenges in engineering integration.

**Table 1.** Aspects of Nature of Scientific Knowledge (Lederman et al., 2014b)

1. Scientific Knowledge is empirical	5. Scientific Knowledge is durable, but subject to change in the light of new evidence
2. Scientific Knowledge is inferential; observations and inferences are different	6. Science is socio-culturally embedded
3. Scientific Knowledge is creative	7. Scientific Laws and Theories are distinct kinds of knowledge
4. Even though objectivity is the goal, subjectivity within scientists is unavoidable	

**Table 2.** Aspects of Nature of Scientific Inquiry (Lederman et al., 2014a)

1. Procedures are guided by the question asked	5. There are multiple methods
2. Data does not equal evidence	6. Same procedures may not get the same results
3. Explanations are developed from data and what is already known	7. Procedures influence results
4. Investigations begin with a question	8. Conclusions need to be consistent with data collected

At the same time, students can understand the differences between science and engineering (Bybee, 2011; Barak et al, 2022) and refer briefly to the nature of engineering (NOE) (Antink-Meyer & Brown, 2019), as shown in Figure 1.

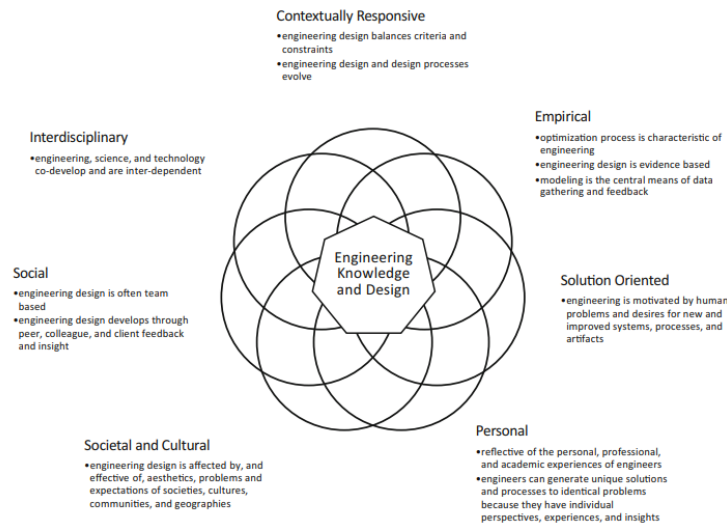

**Figure 1.** Nature of Engineering (Antink-Meyer & Brown, 2019)

The differences between science and engineering we wish to focus on our project, are presented in Table 3, based on the works of Bybee (2011), Antink-Meyer & Brown (2019) and Barak et al (2022).

**Table 3.** Basic Differences between Science and Engineering

Characteristic	Science	Engineering
Questioning	Questions about phenomena, those that could be answered with the existing knowledge and those are yet to be answered	Questions on problems that must be solved, using the existing scientific knowledge, clarify the problem and set the constraints.
Creativity	Seeking for creative ideas to formulate new explanations	Searching for creative ideas, efficiently implementable
Objectivity	Seeking neutrality and avoiding bias	Applying a rational approach to the design process
Laws and theories	Development of theories that provide explanation of how the world works	Provide systematic solutions to problems, based on scientific knowledge and models
Socially embedded	Research is affected or guided by societal, political, or economic factors	Engineering is based on real-world problems that guide the solutions taken

Regarding the increasing STEM instruction and the inclusion of engineering in teaching and learning to high school students, we agree with Antink-Meyer & Brown (2019) that “the relationships between NOS and NOE are in need of explication and argument. We need to promote a discussion about NOS, engineering, and the relationship between them, without misrepresenting engineering as a subdomain of science or as an oversimplification of itself”. That is why NOE is also included in the objectives of our project.

### 3. Method

Eleven high school students participated in a STEM summer camp at a STEM center in Thessaloniki, Greece, during one week in June 2024. The group consisted of four girls and seven boys. While the students' gender is not analyzed in relation to the project outcomes, it is worth noting the ongoing importance of encouraging girls to participate in STEM initiatives, as research shows that when they do, they perform successfully (Merayo & Ayuso, 2023). Regarding their age distribution, five students (two girls and three boys) had completed 7th grade (age 13), four students (one girl and three boys) had completed 8th grade (age 14), and the remaining three students (one girl and two boys) had completed 9th grade (age 15).

The students worked over five days, from 9:00 a.m. to 3:00 p.m., amounting to a total of 30 hours, to address a problem: designing and implementing a parachute with specific parameters and studying its descent using physical computing methods. The project's primary focus was to teach physics concepts, specifically acceleration, gravitational acceleration, the distinction between acceleration and speed, and forces, along with mathematical concepts such as graph interpretation. Additionally, the project aimed to explore aspects of the Nature of Science (NOS) and guide students to differentiate between science and engineering while applying the Engineering Design Process (EDP).

The research questions guiding this study were as follows:

1. Can students connect the relevant physics and mathematics concepts to the EDP process through a STEM project?
2. Can students articulate the NOS aspects that emerge during the project?
3. Can students implement the project following the EDP under the supervision of two educators?

The two educators acted as both instructors and researchers. They met daily to discuss the students' progress and adjusted plans as necessary. While the project had been implemented in previous years (authors' reference), it had not previously employed the EDP as a methodology. The instructors were experienced in running this project, and while the students had some prior exposure to STEM education, they had never worked on an integrated project or used the EDP as a framework.

Throughout the project, students applied physics and mathematics concepts to solve a real-world problem, utilized appropriate instruments for data collection, and discovered how knowledge from various school subjects could be integrated to address a given question. The project encouraged iterative problem-solving as students encountered

challenges, requiring them to complete new cycles of the EDP. This iterative process aimed to boost students' confidence in handling complex tasks while enhancing their engagement and motivation.

This qualitative study collected data from students' answers to short quizzes, plenary discussions, and project diaries, which included their designs. Although much of the project took place in plenary sessions, students also worked in smaller groups and individually during specific stages.

To assess the primary cognitive objective—students' understanding of the physics concepts—they completed a science quiz at both the beginning and the end of the summer camp (see Appendix 1). Additionally, the final two hours of the camp were audio-recorded, and students' engineering diaries were photographed and analyzed for evidence of their understanding of the key concepts.

The timetable of the summer camp follows in Table 4.

**Table 4.** Timetable of the Project

Day	Task	Duration (in hours)
Monday	Define the problem	1
	Research & Discussion on the problem	3
	Imagine and design the solution on paper and decide on the materials that will be used, software that will be used presented.	2
	Building a prototype: creating the canopy shape, using Tinkercad and Pepekura software	3
Tuesday	BBC micro:bit instruction, basic coding blocks and the accelerometer	2
	Discussion on the problem, the parameters we study and what we should compare	1
	Testing that the canopy work, make improvements, imagine and designing solutions on how to connect the canopy with the rest of the parachute, and what materials to use for it. Finalize the "basket" to put the device in	2
Wednesday	Deciding on building a ring. Measuring the dimensions, using the proper instrument	2
	Designing the ring on Tinkercad and 3d printing it (test/improvements)	2
	Designing the program for gathering data during the test fall	2
Thursday	Study of fall on BBC micro:bit (testing of the program, make improvements)	2
	Discussion on physics concepts used	1
	Getting the parachutes ready, write the expected results	1
	Launch time: Release of the parachutes, recording and analyzing data	2
Friday	Prepare graphs, compare them and draw conclusions	2
	Aftermath of the project: discussion on STEM disciplines, NOS & NOE aspects, students' impressions	2
<b>Total</b>		<b>30</b>

The literature highlights that an efficiently implemented Engineering Design Process (EDP) not only enhances students' understanding of scientific concepts but also provides experiential, real-world learning opportunities (Arik & Topcu, 2023; Cunningham & Carlsen, 2014; Lin et al., 2021). For this reason, the EDP serves as the foundation of our work, with all tasks structured around its framework. Figure 2 illustrates the specific structure of the EDP as applied in this study. This framework was utilized both for the overarching project and for individual tasks within it.

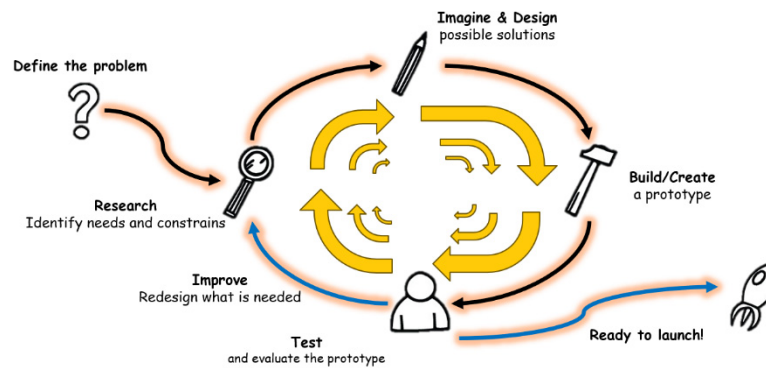

**Figure 2.** The Engineering Design Process Used in the Present Work

Several challenges were anticipated due to the varying levels of students' expertise in STEM practices, physics, and mathematics, stemming from their prior experiences and school-based knowledge. In Greece, science lessons are predominantly theoretical rather than practical, which can make it difficult for students to connect abstract concepts to real-world applications. The integrated nature of the project was also a novel experience for many students, leading to initial skepticism among some participants.

Furthermore, as the students did not know each other prior to the camp, group dynamics and collaboration were critical factors that instructors considered during the camp's design. To address potential conflicts, we assigned specific roles within groups. To maintain engagement and reduce frustration during setbacks, we prepared supplementary presentations with material designed to help students overcome challenges.

Given that students had no prior experience with the Engineering Design Process (EDP), we structured the project to guide them through each step. Each phase concluded with a plenary session to review progress and integrate components of the project. It is important to note that engineering is not part of the standard curriculum in Greek schools, and STEM integration was only recently introduced in courses like the "Soft Skills Laboratory" in primary and junior high schools. However, due to insufficient teacher training and inadequate equipment, these initiatives have yielded limited outcomes (Theodoropoulou et al., 2023).

As a result, most students had limited exposure to STEM activities and were unfamiliar with the EDP. This necessitated instructor-led guidance through each stage. Consequently, we focused not on assessing independent application of the EDP, but rather on evaluating whether students could follow instructions and adopt new ways of thinking. As noted in the literature, we did not expect students to ask many questions about the process or take significant initiative (Lin et al., 2021).

A detailed description of each day and stage of the project follows in the next section.

## 4. Implementation

All students participated in the summer camp after they finished their final written exams in their schools, usually a demanding process. This means that our project needs to be provoking and challenging, relating to real world problems.

### 4.1 Definition of the Problem, Initial Research, and Important Knowledge

The summer camp begins with an introduction to the project and the definition of the problem. Students are tasked with designing and building a parachute capable of delivering sensitive and fragile materials, such as medicine in emergency situations. They are encouraged to use everyday materials, such as paper and string, as well as any tailor-made components they can design using 3D printing.

To support their work, students are provided with resources, including activities from NASA (note 1) and ESA (note 2), particularly those related to the CanSat (note 3) competition, which offers guidance on parachute construction. The egg-drop challenge is also presented as an illustrative example of delivering fragile materials safely (note 4). Additionally, relevant reading materials are provided (Leavy et al., 2021; Gluck, 2003). Although the camp is

conducted in Greek, the students, being high school learners, are proficient in reading English and do not face difficulties with the provided texts. While studying these resources, students are instructed to identify and note the various components of a parachute and brainstorm potential design approaches.

After students have collected and reviewed the relevant information, a plenary session is held to discuss the key physics concepts involved in the problem. These include speed, terminal velocity, acceleration, weight, and air resistance (drag force) and their respective roles in the parachute's operation. To simplify the analysis, complex mathematical equations are avoided. Instead, we assume that the only forces acting on the parachute are:

- Drag force: Generated by the interaction of a moving solid body with a fluid, directed upward.
- Weight: The gravitational force acting downward.

Thus, the total force acting on the parachute is:

$$F_{total} = w - F_{drag} \quad (1)$$

To avoid another force due to the wind, we decided to find a windless place when releasing the parachute.

In discussing the shape of the canopy, we considered the drag force, given from the equation.

$$F_{drag} = \frac{\rho u^2 A c_d}{2} \quad (2)$$

where  $\rho$  is the mass density of the fluid,  $u$  is the speed of the object relative to the fluid,  $A$  is the cross-sectional area of the canopy, and  $c_d$  is the shape dependent drag coefficient.

Through the equation, students can comprehend that the drag force is initially zero, as the velocity is zero at the start. As the parachute accelerates, its velocity increases, leading to a corresponding increase in the drag force. When the total drag force becomes equal to the weight of the system, the net force acting on the parachute is zero. At this point, the parachute ceases to accelerate, and its velocity stabilizes at a constant value. This constant velocity, known as the terminal velocity, is the speed at which the parachute descends to the ground. Notably, the drag force cannot exceed the weight, as this would imply upward acceleration of the parachute, which is physically implausible.

The concept of a non-constant force that progressively increases until reaching an equilibrium value is unfamiliar to most students. To help students visualize the interaction of the two forces—the constant force (weight) and the variable force (drag)—we instructed them to examine a diagram depicting these forces as functions of time acting on the parachute. An illustrative example is presented in Figure 3.

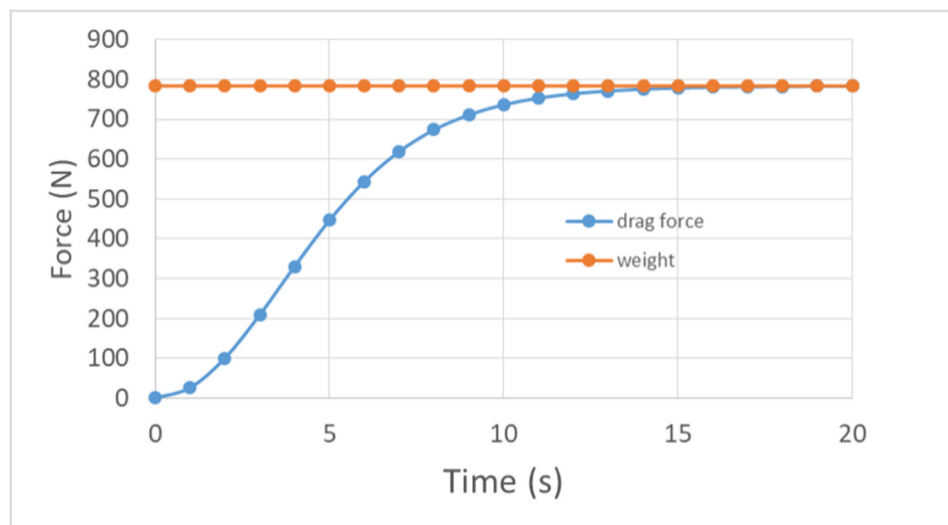

**Figure 3.** Graph of the Drag Force and Weight during Time to Visualize the Non-Constant Nature of the Drag force (retrieved from <https://openoregon.pressbooks.pub/bodyphysics/chapter/graphing-full-skydiving-motion/>)

Equation (2) is difficult for students, but particularly important for the canopy shape. The drag coefficient is not constant but depends on the Reynold number ( $Re$ ), related to the air flow type. A high Reynold number is related to turbulent flow, as in our case. So, the bigger the value of the drag coefficient, the bigger the drag force is, and the

parachute touches the ground softly. It was easier for students to discuss that with the table of values and body shapes, shown in Figure 4.

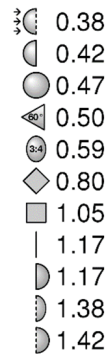

**Figure 4.** Table of Drag Coefficients in Increasing Order, of 3D Shapes at Reynolds Numbers between  $10^4$  and  $10^6$  with Flow from the Left. Source: [https://en.wikipedia.org/wiki/Drag\\_coefficient](https://en.wikipedia.org/wiki/Drag_coefficient)

After thorough discussions during the plenary session, key decisions were made. It was agreed to use paper for canopy due to its compatibility with printing the desired shape. Alternative materials, such as plastic bag material and foil, were considered but ultimately rejected. Furthermore, it was concluded that the final shape depicted in Figure 3 was the most suitable for achieving the maximum drag coefficient.

Prior to working in small groups of two or three, students were informed of the tasks scheduled for the following day. Specifically, they would design the canopy using Tinkercad and measure a physical quantity with the BBC micro:bit. As the microcontroller would be incorporated into the parachute, students were tasked with devising a method to protect it from the impact upon landing. This requirement simulated the challenge of safeguarding real fragile objects in the project.

For the remainder of Day 1, students collaborated in their groups to sketch proposed designs for the parachute on paper. While they did not finalize a solution by the end of the day, they were adequately prepared to commence work on the canopy design the next day.

#### 4.2 Canopy Design

Regarding the canopy, students had determined its shape and agreed that it should have a large surface area with minimal weight, opting for a light material such as a paper sheet to avoid adding significant mass to the system. However, creating a semi-spherical shape from a sheet of paper posed considerable challenges. To address this, students were encouraged to experiment initially with physical sketches and subsequently with design software. To approximate the selected shape shown in Figure 4, a design inspired by a hexagonal circus tent was adopted. Students were introduced to the process of creating this design using Tinkercad, a beginner-friendly software for 3D modeling.



**Figure 5.** Design of the Canopy at Tinkercad and Its Development at Pepakura



As with every stage of the project, students displayed varying levels of proficiency and experience, both in using the technology and in their conceptual understanding. More experienced students independently explored and successfully completed the design, while others required additional guidance to achieve the desired results. After completing their designs in Tinkercad, students used Pepakura, a software tool that converts 3D models into 2D development layouts. The resulting layouts are presented in Figure 5.

As discussed on the previous day, the canopy was to be printed on paper. However, decisions regarding the size and quality of the paper were pending. To proceed, students first needed to design and prototype a basket that would be attached to the parachute and serve as a carrier for the sensitive material. For the purposes of the prototype, the basket would house the micro:bit, which would transmit data during the fall.

#### 4.3 Basket Shape and Size

The micro:bit board has dimensions of 51.60 mm (width)  $\times$  42.00 mm (height)  $\times$  11.65 mm (depth), as shown in Figure 5, and a weight of 9.62 g. A radio-transmission system can be established using two micro:bits: one as a receiver connected to a PC, and the other as a transmitter. In this configuration, the transmitting micro:bit must be battery-powered. The battery system, consisting of two AA batteries, weighs 64.48 g. The combined micro:bit and battery system would be attached to the lower part of the parachute and transmit data to the receiver during the fall. Consequently, the parachute design must account for the protection of the electronic components.

Students proposed various solutions for securing and protecting the system. They suggested tying the basket to the canopy with string and using protective materials such as small balloons, styrofoam, bubble wrap, or similar cushioning elements. Three students specifically proposed using a plastic cup as the basket. Additionally, preliminary trials were conducted using playdough of equivalent weight to simulate the micro:bit and battery system. These trials allowed students to observe the falling behavior with the proposed materials, and they recorded their observations.

It was emphasized that the micro:bit is capable of measuring acceleration along all three axes (x, y, and z), and the results are sensitive to direction. Students were introduced to the programming of the micro:bit and the functionality of its accelerometer. They then tested the directional sensitivity of the device. The coordinate axes of the BBC micro are illustrated in Figure 6.

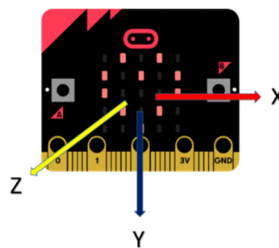

**Figure 6.** Coordination Axis of BBC micro:bit

In discussions with the students, it was decided to simplify the process for those less familiar with interpreting diagrams. The two axes would be kept as horizontal as possible, while measurements would be taken along the third axis. Following this decision, students proposed a tailored solution, suggesting a custom 3D design specific to the requirements of the project.

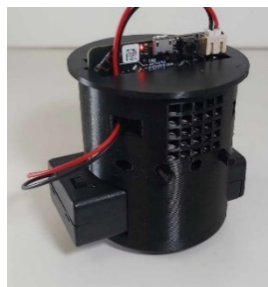

**Figure 7.** Placement of the Micro:bit and the Battery-Case in the Lower Part of the Parachute

Working initially in small groups and subsequently through collective discussion, the students finalized the design, depicted in Figure 7. The design resembles a cup with a dedicated compartment for the micro:bit and the battery system. Students created a detailed sketch of the case on paper, which was then translated into a 3D model by the instructor using Fusion 360. The finalized model was 3D-printed and made available for use by the next day. The completed case weighed 45.04 g.

Bubble wrap and rubber bands were also employed to ensure the safety of the devices, adding 7 g to the total weight. Consequently, the overall load weighed 126.14 g. All measurements were conducted three times, and the averages were calculated using an analytical scale with a precision of 0.01 g.

#### 4.4 Connection between the Upper and Lower Parts of the Parachute

The next step involved determining the method for connecting the upper part (canopy) and the lower part (basket) of the parachute. The simplest approach was to use strings. However, several design considerations arose: how to securely attach the strings to the basket, the optimal number of strings, and their appropriate length.

Through a process of designing, testing, iterative improvements, and group discussions, students decided to use six strings—one for each side of the hexagonal canopy. The strings were approximately 50 cm long, chosen to ensure balance and symmetry for the basket. Initially, students proposed making holes in the plastic cup to attach the strings, but this approach proved impractical as it risked compromising the structural integrity of the basket.

When the idea of using a custom-designed solution was suggested, students proposed designing a 3D-printed ring to securely attach the strings. This innovative approach was implemented, and the final design, including the process, is illustrated in Figure 8.

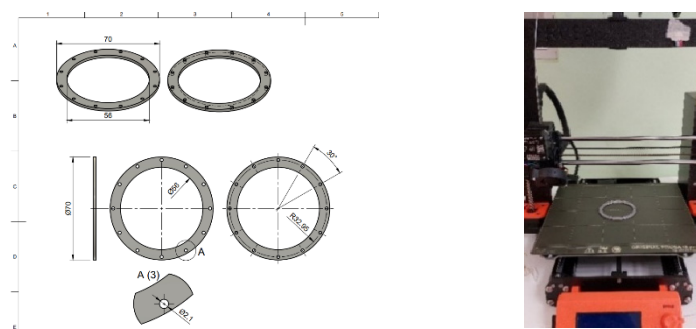

**Figure 8.** Ring Design in Fusion and Printing in 3D-printer

#### 4.5 Completing the Parachute

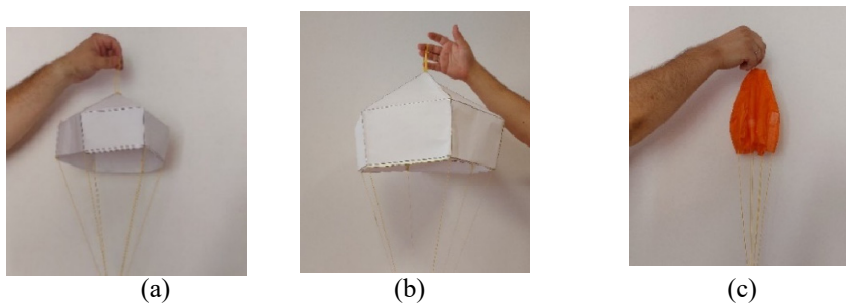

(a) from 80g photocopier paper 25cm diagonal length

(b) 50cm diagonal length, and

(c) tissue paper 25 cm diagonal length.

**Figure 9.** Parachute Canopy

During discussions on scientific investigations, particularly the principle of changing only one parameter at a time while keeping others constant, it was decided to standardize all variables except for the canopy. Three different parachutes were constructed for this purpose. Two parachutes were made from the same material (80 g/m<sup>2</sup> photocopy paper): one with a diagonal length of 25 cm (Figure 9a) and the other with a diagonal length of 50 cm (Fig. 9b). The third parachute was made from tissue paper with a diagonal length of 25 cm (Figure 9c).

At this stage, students were asked to identify which parameter of the drag force varied across the parachutes, based on Eq. 2. Older students from Grade 9 correctly identified that parachutes (a) and (b) differed in cross-sectional area, while parachutes (a) and (c) differed in weight but had no other distinguishing parameter. Two students from Grades 7 and 8 were able to paraphrase this reasoning but admitted they would have been unable to articulate it without first hearing the explanation. No student was able to address the role of fluid density in the discussion.

Students attached six strings, each 50 cm long, to each of the three parachutes and tested their performance by dropping them from a height of approximately 2 m. A 50 g load of playdough in a plastic cup was used as the payload. During testing, students observed that parachute (c), made of tissue paper, introduced additional variables. Unlike the other parachutes, it had an inconsistent shape, expanding during the fall, and as a result, the effective height of the fall varied. Consequently, it was decided to exclude parachute (c) from the data collection and focus on comparing parachutes (a) and (b).

Parachute (a) weighed 16.95 g, while parachute (b) weighed 32.70 g. The final parachutes selected for testing are shown in Figure 10.

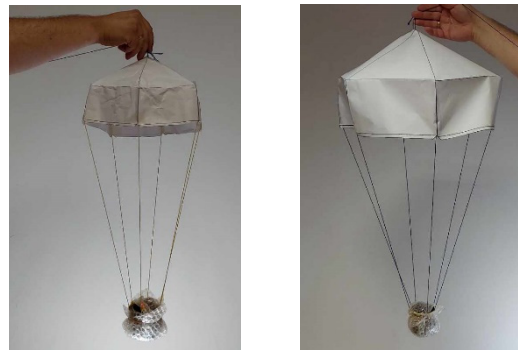

Figure 10. Final Parachutes (a) and (b)

#### 4.6 BBC micro:bit Programming



Figure 11. Program of the Transmitter micro:bit

On the first day, students participated in an introductory session on programming the micro:bit using the MakeCode interface (makecode.microbit.org), as most students were unfamiliar with the platform. Students were then guided in groups to gradually develop the program, with more experienced students assisting beginners by explaining the function of each programming block and facilitating discussions about the transmitter and receiver programs. The transmitter program is depicted in Figure 11.

To deepen their understanding of the accelerometer's functionality and the raw data it measures, students conducted a free-fall experiment. The micro:bit was dropped from a height of approximately 2.5 m onto a cushioned surface (pillows), and the acceleration along the y-axis was recorded in milligravities (one-thousandth of the acceleration due to gravity at sea level). The processed data is presented in Figure 12, where time (in seconds) is plotted on the x-axis and y-acceleration (in  $m/s^2$ ) on the y-axis.

Using the equation  $h = \frac{1}{2}gt^2$ , the height of the fall was calculated to be 2.6 m, which matched the measured height. This provided an opportunity to engage students in a discussion about the importance of processing raw data to produce a graph that "makes sense" in a physical context, as one student aptly commented.

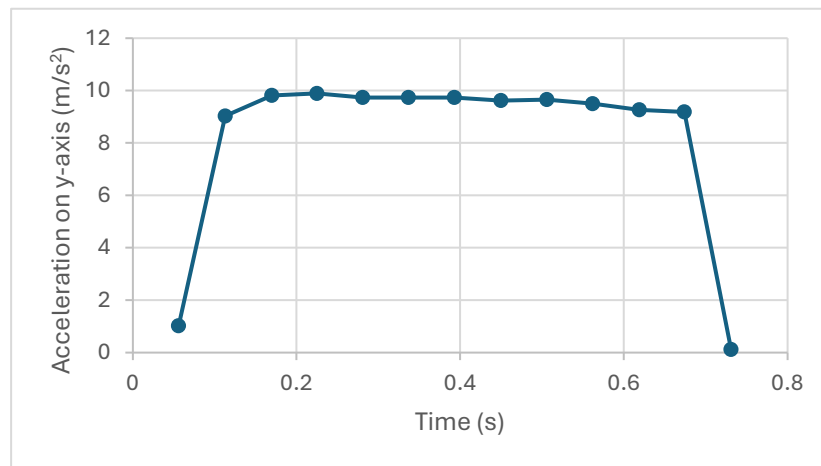

Figure 12. Free Fall of the Micro:bit

#### 4.7 Launch Time and Push Button Mechanism

On the final day, the parachutes were tested through live launches. The release height was approximately 6 m (precisely measured at 5.35 m using a laser meter). This provided an opportunity to incorporate another measurement instrument into discussions, emphasizing the selection of tools based on the required measurement precision. Each parachute was released three times, with data collected for each trial. Students then returned to the classroom to process the data and draw conclusions.

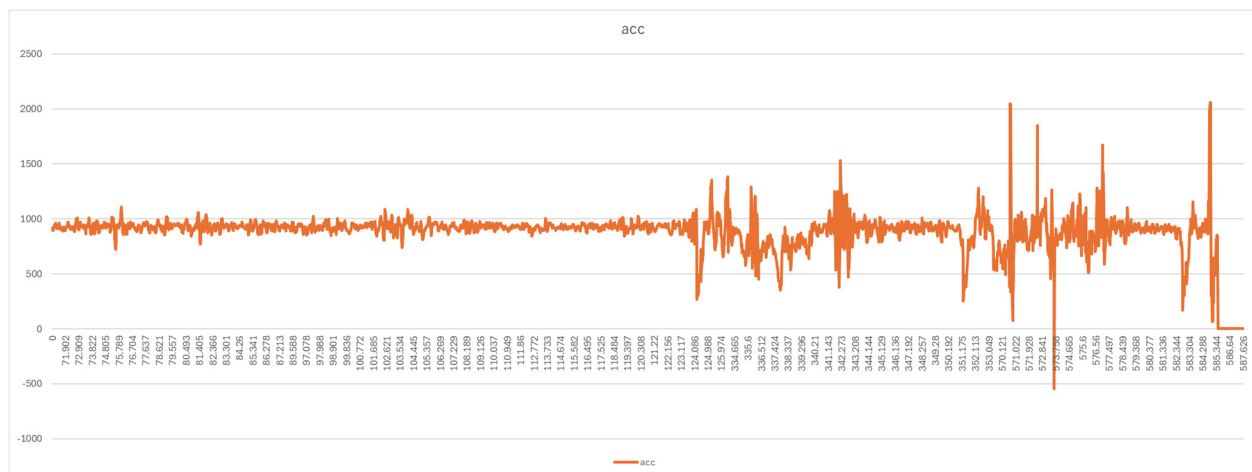
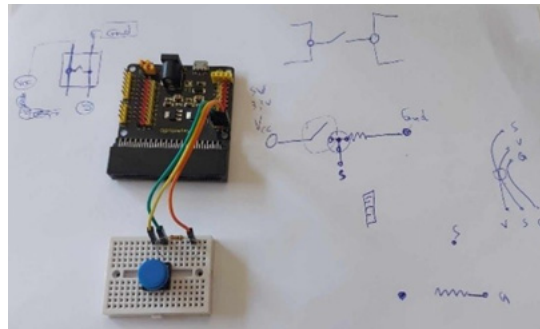

Figure 13. Graph of Raw Data of Parachute (b) after Three Falls

When plotting the graph, as shown in Figure 13, students encountered difficulty identifying the exact points where the fall began and ended in each trial, as these were not clearly distinguishable from the recorded data. To address this issue, students were invited to brainstorm potential solutions. The majority suggested implementing a release mechanism that would allow the micro:bit to record data only after being deployed.

After further discussions, considering the need for a feasible, self-designed solution and the available resources in the electronics inventory, a decision was made to create a button-trigger mechanism. This mechanism would send a specific, distinct value to the recorded data when pressed, marking the precise moment of release. While this may not represent the optimal solution from an engineering perspective, it was sufficient for the purposes of the project.

Students were familiar with basic electric circuits but lacked knowledge of complex electronics. Therefore, we taught them how to connect the button as shown in Figure 14. The setup included a button, a raster, a shield, and three M2F jumper wires. Although we briefly introduced the concepts of pull-up and pull-down resistors on 3.3V boards, this topic was beyond the students' current level of understanding.



**Figure 14.** Connectivity of the Button Mechanism (student notebook)

The final receiver system is displayed in Figure 15. We conducted three trials for parachutes (a) and (b) and subsequently processed the data to draw conclusions. The person holding each parachute was also responsible for controlling the button mechanism, pressing it at the moment of release and again when the parachute reached the ground.

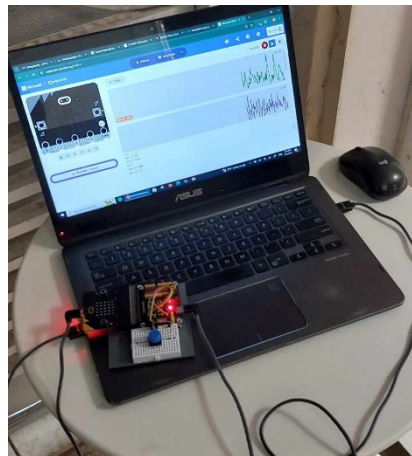

**Figure 15.** Receiver System

#### *4.8 Data Processing and Drawing Conclusions*

Students worked in groups to select the necessary data, process it, and present the results on a common axis, as illustrated in Figure 16.

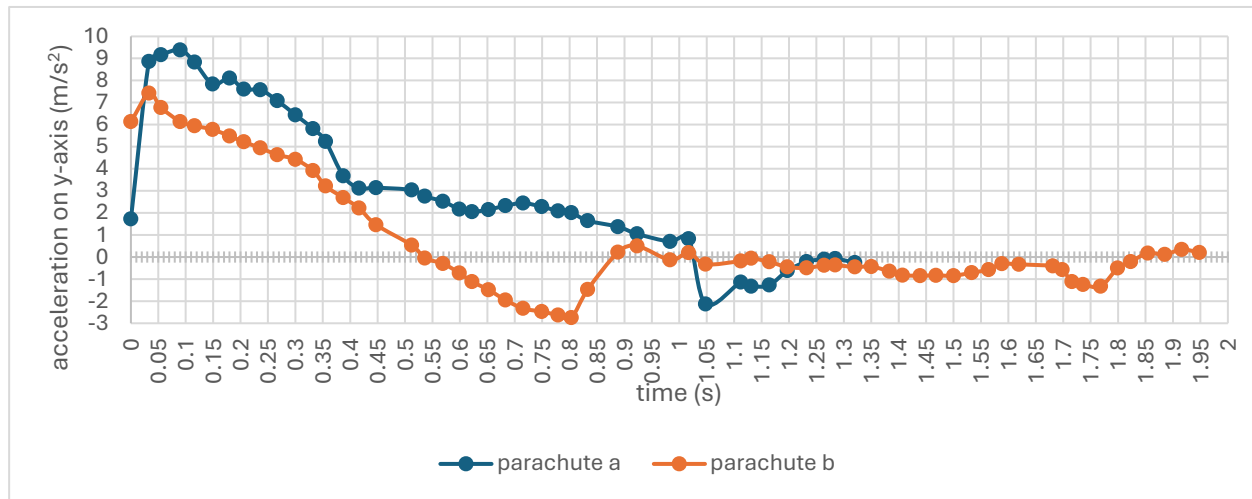

**Figure 16.** Release of the Parachutes, Graphs for the Two Parachutes in a Common Axis

Upon release, both parachutes took some time to reach terminal velocity. During this period, the acceleration decreased as the drag force gradually approached the weight. Once the forces were equal, the terminal velocity was achieved. The graphs for both parachutes followed a similar pattern, but we observed differences in their behavior:

- For parachute (a), terminal velocity was reached shortly before it touched the ground.
- For parachute (b), terminal velocity was achieved around 1 second after release.

In terms of flight time:

- Parachute (a) reached the ground at 1.35 seconds.
- Parachute (b) reached the ground at 1.95 seconds.

Neither parachute exhibited bouncing upon landing. Calculations showed that the time for free fall from the given height would be 1.03 seconds, indicating that the descent of parachute (a) closely resembled free fall.

Focusing on the parameter under investigation, we concluded that a larger canopy results in a longer descent time. Consequently, parachute (b) is more suitable for transporting sensitive materials, as it aligns better with the initial problem specifications and lands more softly.

Regarding the terminal velocity, according to Equation 2, this is:

$$F_{drag} = \frac{\rho u^2 A c_d}{2} \rightarrow u = \sqrt{\frac{2F_{drag}}{\rho A c_d}} \rightarrow u_{term} = \sqrt{\frac{2mg}{\rho A c_d}} \quad (3)$$

because  $F_{drag} = mg$  at the terminal speed

From Equation (3), students calculate did the following calculations:

$w_a = m_a g = 143.09 \times 10 / 1000 = 1.4309 \sim 1.43N$  for parachute (a) and  $w_b = m_b g = 159.11 \times 10 / 1000 = 1.5911 \sim 1.59N$  for parachute (b)

$\rho = 1,184kg/m^3$  (note 5)

$A_a = 12 \times \frac{6.25 \times 10.8}{2} \times 10^{-4} = 0.0405m^2$  for parachute (a),  $A_b = 12 \times \frac{12.5 \times 21.6}{2} \times 10^{-4} = 0.162m^2$  for

parachute (b)(note 6)

$c_d = 1.42$  (see Figure 4)

So,  $u_a = 6.48$  m/s and  $u_b = 3.42$ m/s.

The speed of the free fall from that height is equal to  $u_{free} = \sqrt{2gh} = 10.24$  m/s.

Students of grade 9 did the calculations easily, whereas students from grades 7 and 8 faced problems handling the equations, so we decided not to go further with them.

The final two hours of the summer camp were dedicated to feedback and discussion of the students' experiences. During this time, students completed their "engineering diaries" (see next paragraph) and finalized their reports on what they had learned. We also engaged in a detailed discussion about the Nature of Science (NOS) aspects. Additionally, students retook the physics concepts test administered at the beginning of the week (see Appendix 1).

## 5. Discussion and Results

### 5.1 Comprehension of Physics and Mathematical Concepts

In the pre-test – a 10-minute quiz (see Appendix 1) – students were assessed on their understanding of forces, air resistance/drag force, weight, acceleration, speed, terminal velocity, and the difference between acceleration and speed. The test also included some mathematical calculations and required students to interpret a diagram.

The results showed that 9th-grade students performed better than their younger peers due to their greater familiarity with these concepts, while 7th-grade students lacked knowledge of many topics or ways of thinking.

- **Speed:** Most students understood speed qualitatively, defining it as how fast a body moves. However, only half could recall its defining equation.
- **Forces:** While most students recognized weight and air resistance as forces, they struggled to describe the characteristics of gravitational force. Few students (four in total) identified it as a vector resulting from the interaction of two bodies, likely because this was part of their curriculum in the previous year.
- **Air Resistance:** Students qualitatively understood that air resistance opposes motion, but they failed to identify its direction accurately, often assuming it to be constant regardless of velocity.
- **Acceleration:** None of the students defined acceleration correctly. For acceleration of gravity, students had heard of it but misunderstood its nature, often referring to it simply as "gravity" without comprehension of its meaning. It is worth noting that acceleration and acceleration of gravity are covered more thoroughly in the 10th-grade curriculum.
- **Friction:** Students incorrectly categorized friction as a fundamental force, failing to understand that it occurs when two bodies are in contact.

The explanation of these concepts was integrated gradually throughout the project and its specific tasks, as described earlier. During discussions, students were encouraged to use the relevant physics concepts in their explanations, with peers correcting any errors. This approach fostered collaborative learning and facilitated organized scientific discussions. By the end of the week, all students were able to articulate the concepts correctly.

In the post-test, taken at the end of the camp, students demonstrated significant improvement:

- Most students correctly represented air resistance acting on the parachutes (question 3).
- They accurately attributed a Ferrari car's ability to achieve high velocity quickly to higher acceleration (question 4).
- While students understood that acceleration and speed are distinct, some struggled to explain the difference clearly.
- All students recognized terminal velocity as the speed at which the parachute touches the ground.

Notably, students overcame several alternative misconceptions without prior formal instruction in these concepts at school.

The results of the pre- and post-tests are summarized in Table 5.

**Table 5.** Results Related to Physics Concepts

Concept	Pre-test	Post-test
Speed	All students defined it correctly, as how fast a body moves, 6 wrote the equation	All students defined it correctly, as how fast a body moves, 8 wrote the equation correctly
Acceleration	Did not define the concept	7 defined the concept as how the speed changes. All noted it is tracked by the accelerometer
Acceleration vs Speed	Cannot define the difference, one student noted “they have to be different, because we don’t use different names of the same concept but cannot say why”	All students knew it is different, only 5 defined the difference correctly. They all knew that the micro:bit measures only the acceleration
Weight	7 knew it is a force, 5 drew its vector	All students knew it is a force and drew its vector correctly
Drag force/Air resistance	No student drew it, 5 students understood what it means, 8 knew it is a force	8 students drew it correctly in different phases of the parachute fall
Acceleration of gravity	6 students described it as a measurement of gravity, 5 thought it is a force	All students defined it as a “kind of acceleration” and it “different on each planet”. No student thought it is a force.
Terminal speed	Never heard the concept	All students replied that it is the velocity the parachute reaches the ground. They did not understand all parts of its equation and 4 noted they were not confident to use and control the variables

Students initially lacked confidence in working with Equation 2, as they struggled to manage multiple variables. In the pre-test, only four students were able to determine the equation for time during free fall, whereas seven students succeeded in the post-test. In the post-test, only the three 9th-grade students and one 8th-grade girl successfully solved the given equation for a specific variable. Similarly, while only four students could correctly interpret a graph in the pre-test, all students achieved this skill in the post-test.

Although students had no prior experience working with a three-axis coordinate system, most adapted quickly due to their familiarity with two-axis systems. Nine students successfully identified the relevant acceleration component during their free fall experiment. Even though only three students fully understood how the accelerometer worked and what it measured, all students were able to locate the terminal velocity points on the graph. These results are consistent with the findings of Faber et al. (2020), who highlighted that summer camps can significantly boost students’ engagement and motivation, leading to improved focus and learning outcomes.

### 5.2 Nature of Science Aspects

NOS aspects were discussed throughout the project and further elaborated in a dedicated session at the end. These discussions are summarized in Tables 6 and 7, where each number corresponds to the aspects outlined in Tables 1 and 2.

All NOSK and NOSI aspects were incorporated into the project through the tasks students worked on. These aspects were discussed during the tasks and revisited in the final session of the project to ensure students felt confident engaging with them. We emphasized the explicit and reflective approach advocated by Abd-El-Khalick et al. (2008), where NOSK and NOSI aspects are explicitly addressed in teaching. Previous studies (Koumara & Plakitsi, 2020) indicate that NOSK and NOSI aspects are not integrated into the Greek science curriculum, a fact confirmed by our students. None had encountered the concept of the nature of scientific knowledge before, though they demonstrated some intuitive understanding of the empirical (#1) and tentative (#5) aspects from their science lessons. For example, one student remarked, “*We never used the term ‘nature of scientific knowledge’ at school, and we never mention any of its aspects, but the empirical aspect is quite obvious for me.*” Similarly, another student noted the tentative aspect, saying, “*We learn about many scientific models that changed throughout history, like the geocentric model, so even though we did not mention it explicitly, I know about it.*”



**Table 6.** NOSK Aspects and How They Emerged into the Project

NOSK aspect	How it was integrated in the project	NOSK aspect	How it was integrated in the project
1.	Observations of the release of the parachute and study of its acceleration through the data	5.	Discussion on the amount and quality of data from the device vs just observing
2.	Through observations, we end up to inferences, which might be different among peers, i.e., the importance of a parameter	6.	How the scientific knowledge is applied in real-world problems, like delivering fragile objects to remote areas
3.	The whole design and implementation, the solving of arising problems (i.e., securely placing the Micro:bit in the cup, the design of the ring and the canopy)	7.	The relation among concepts (i.e., weight and mass through g) does not explain i.e., why an object falls
4.	Discussed as the result of disagreement among different inferences.		

**Table 7.** NOSI Aspects and how They Emerged into the Project

NOSI aspect	How it was integrated in the project	NOSI aspect	How it was integrated in the project
1.	What we study leads us to guide each stage of the project (i.e., how to design the parachute, which instruments to use)	5.	Using the experimental method & literature research
2.	We need to process the data we get, to find evidence	6.	Not getting the same results during the release of the same parachute
3.	Learn physics concepts and answer our research questions through data and what is already known	7.	Instrument errors, their accuracy, how to keep accelerometer axis x and z fixed
4.	The project is developed through a series of successive questions, i.e., “how can I design a parachute to land our desired subjects safely?”	8.	Discussed that explanations are developed from data

The creative (#3), cultural (#6), and objective (#4) aspects were the most surprising to students. One commented, “*I had never thought about creativity in science, but on the other hand, I didn’t know how new scientific knowledge is produced.*” Another added, “*Objectivity would sound surreal in science, but after the COVID period, I can understand it better.*” Finally, a student reflected on the cultural aspect, stating, “*We never thought that science has such an impact on society, even though of course it does, but we never saw it that way at school.*”

Regarding NOSI aspects, all students were unfamiliar with them, though three students who had experience with inquiry-based learning recognized similarities. One student noted, “*This is the scientific method we follow, and it makes perfect sense. I hadn’t heard them described this way, but this is what we do.*” The remaining eight students, who lacked practical work experience in their science lessons, found it more challenging to connect initially but grasped the concepts during the project. One student remarked, “*Even though I do not have similar experience at school or another project, I feel that I became familiar with it. Surely, I wish I had more experience in lab work, but I will keep these concepts in mind.*”

Students acknowledged the need to revisit NOSK and NOSI aspects during their school years to fully comprehend and retain them. Nevertheless, this project served as a strong introduction. Additionally, the project demonstrated how STEM activities can provide a natural space to explore these elements.

In the final hours of the project, students explored NOE aspects, focusing on the differences between science and engineering, as outlined in Table 3. Students identified both similarities and differences, such as the iterative methods both fields use but their distinct objectives. As Antik-Meyer & Brown (2019) explain, scientists aim to obtain reliable

measurements, analyze data, and test relations between quantities within the framework of scientific concepts and natural phenomena. In contrast, engineers focus on creating products that meet specific requirements. Our project intentionally guided students to act as scientists by studying and applying physics and mathematics concepts, then transitioning to engineers by using those concepts to solve real-world problems through design. This distinction was highlighted throughout the project and reinforced in discussions.

### 5.3 Engineering Design Process Through the Implementation of the Project

The Engineering Design Process (EDP) was a central component of the project. Students had no prior experience with EDP, including the three who had participated in practical science lessons, as those primarily involved scientific experiments limited to the first or second levels of inquiry (Herron, 1971). Engineering is not included in the Greek curriculum, nor is it widely taught in secondary education globally. To address this, the summer camp design provided substantial guidance to help students navigate the project. Without guidance, they struggled to initiate or progress to the next step, as noted in similar studies (Lin et al., 2021). However, with structured provocations and support, students successfully completed the tasks.

One student reflected, *“I feel that through the EDP, we were guided to complete the project. It guided our steps, our thinking, and showed that errors are not to be blamed but are part of the process.”* Another added, *“Without the EDP, we would have argued and struggled to decide how to continue and what to do next.”* A student emphasized the value of sketching before building, saying, *“It made me think twice about whether what I wanted to build made sense. It also helped me present my ideas to peers. Otherwise, we would just disagree without knowing why.”* Initially hesitant, one student noted, *“At first, I was eager to start building a prototype and didn’t like the process, but very soon, I understood the importance of designing on paper first.”* Despite recognizing the time investment required, all students expressed willingness to use EDP in future projects.

Students also maintained “engineering diaries” (Kelley, 2011) to document their progress at each stage. These diaries included initial sketches alongside final designs, enabling students to visually track their development. Notes on design alterations and their impact on the parachute, explained using physics concepts, were also recorded. One student remarked, *“This is the best keepsake I could get! It is full of my work and notes, so I can remember the project we did.”* Completing their records after each task became a source of pride for students. The diaries served as a tangible representation of the EDP, integrating the stages of designing, building, testing, and improving into a cohesive narrative.

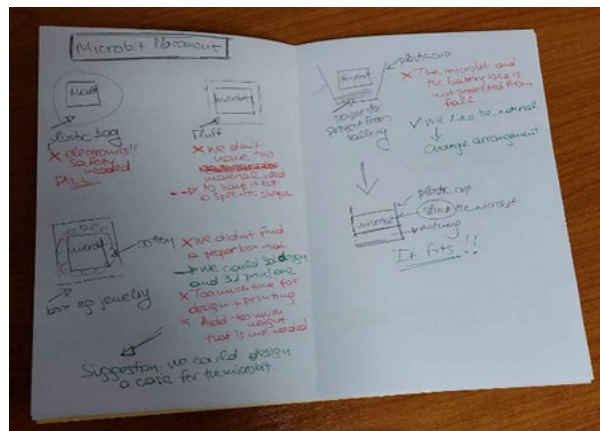

**Figure 17.** Example of an Engineering Diary Report (translated in English for the readers)

We chose not to assign specific roles for the project because it was a short-term endeavor, and all students were actively involved in every aspect. Naturally, some students gravitated more toward certain parts of the project, influenced by their personal interests and prior experiences. While students were unable to independently organize the next steps, they remained engaged and were able to follow the pace we set, aligning with observations from Sulaeman et al. (2021) and Wind et al. (2019).

From the instructors’ perspective, this was our third time running the summer camp. It is worth noting how we applied the Engineering Design Process (EDP) to refine the project and provide better support for our students. Each iteration of the camp represented a new cycle of the design process, allowing us to improve materials, methods, and

overall implementation. For instance, previous challenges taught us valuable lessons. In earlier runs, a micro:bit was damaged during a fall when using a plastic cup, prompting us to explore more durable designs. Additionally, connectivity issues between the micro:bit and a PC were problematic. Initially, we attempted a Bluetooth connection with a single micro:bit, but the data proved unreliable. As a result, we switched to a more stable radio connection using two micro:bit devices.

Even during this iteration, testing parachute launches the afternoon before the students' experiments revealed design flaws. These issues required us to redesign the casing, making it thicker to ensure durability. However, some elements, such as the ring design, were successful from the beginning and remained unchanged.

Our familiarity with technical aspects has also improved over time. We have increasingly leveraged 3D design and printing technologies, as well as integrated additional electronic solutions, such as the button mechanism. These enhancements not only streamlined the project but also enriched the students' learning experience by providing more opportunities for experimentation with different materials and methods.

#### 5.4 STEM Integration

The concepts from each STEM field are summarized in Table 8.

**Table 8.** The Content of Each STEM Field That Appears in the Project

STEM field	Content
Science	Concepts: force, air resistance, weight, speed, time, space, acceleration. Aspects of nature of science, research methodology
Technology	Tinkercad, Pepakura, 3D-printer, micro: bit, Bluetooth
Engineering	Design process, development of a project, optimal solution
Mathematics	Measuring, calculating, geometry of a construction, interpreting diagrams, data processing

**Table 9.** Development of Soft Skills during the Project

Soft skill	How it is applied in the project
Communication	<ul style="list-style-type: none"> <li>- Oral communication among students to complete the project successfully.</li> <li>- Public speaking, active listening during discussion</li> <li>- Follow written or oral instructions.</li> <li>- Express themselves in the correct scientific terminology</li> <li>- Present their results and making inferences</li> </ul>
Collaboration	<ul style="list-style-type: none"> <li>- Assignment of roles during all stages</li> <li>- Discussion both in plenary and in groups and taking decisions how to continue with the parachute</li> </ul>
Creativity	<ul style="list-style-type: none"> <li>- Design the ring and the canopy</li> <li>- Use the proper instrument during measurements</li> </ul>
Critical Thinking	<ul style="list-style-type: none"> <li>- How to place the micro:bit in the cup</li> <li>- Process data and export final diagrams</li> <li>- Use the proper instrument for measurements</li> <li>- How to maintain the orientation of the micro:bit during the fall</li> <li>- Important parameters to study</li> </ul>

All students demonstrated engagement with the project, which enabled them to overcome initial challenges. According to their feedback, they enjoyed all aspects of the project and expressed a strong desire to participate in similar activities in the future. A 7th-grade student remarked, *“Creating a parachute taught me so much. I used physics to understand how it slows down the fall and math to measure and calculate everything... It was fun and made science feel real and exciting.”* Another 7th-grade student noted, *“I loved that we used so many tools in such a little time. I wish we would do similar projects in the future.”*

Older students provided similarly positive reflections. A 9th-grade student stated, *“Building a parachute was awesome! I knew about air resistance and gravity in physics, but I have never used them together with real math to*

*calculate the shapes and sizes of all parts of it! It was challenging and sometimes hard, but seeing it work was the best part. I feel like a real engineer!"* An 8th-grade student shared, *"Designing the parachute was a cool mix of math, science, and technology. We used physics to understand how it would fall, math to calculate the proper sizes, and technology to implement our designs. It was amazing seeing all these subjects come together to create something that actually worked!"* Another 8th-grade student emphasized the value of structured planning, noting, *"I really enjoyed that we had a written plan and worked as engineers! It helped build my confidence."*

Additionally, the project fostered the development of soft skills, as suggested by Roehrig et al. (2021) and summarized in Table 9. While the assessment of these skills was not a primary research focus, anecdotal evidence suggests that students demonstrated competencies outlined in Table 7. This observation highlights the potential of STEM projects to integrate both technical and interpersonal skill development.

## 6. Limitations of the Project

Students participating in the project came from diverse age groups and possessed varying levels of prior knowledge in STEM, physics, and mathematics. For many, this was their first exposure to a STEM program. Consequently, the primary objective was to activate and encourage collaboration on solving a real-world problem by applying physics and mathematical concepts in an integrated manner. Students were tasked with synthesizing the separately taught physics and mathematics concepts from their school experiences to design products, conduct measurements, and draw conclusions. As they were unfamiliar with the Engineering Design Process (EDP) and had not used it before, it was unrealistic to expect them to initially take initiative or formulate appropriate questions, as observed in similar studies (Lin et al., 2021). Accordingly, the findings presented are reflective of students at a beginner level of STEM engagement.

The time constraints inherent in a one-week summer camp limited the depth and breadth of the knowledge students could achieve. However, it is noteworthy that students might have had more opportunities to experiment with all stages of the EDP – researching, designing, building, testing, and improving – if the project had been implemented over an extended period, such as during a STEM club throughout the school year. Additionally, the scope of the program required focusing on a selection of parameters. For instance, further exploration could have involved experimenting with different canopy materials or configurations of the parachute's lower structure. Additional time would also have allowed for a greater focus on programming the micro:bit or conducting more test drops.

It is important to note that no analysis of participant demographics, such as gender, was conducted. All students were regarded as equally interested in the project and contributed meaningfully to its outcomes.

## 7. Conclusions

Building a parachute as part of a STEM project provided students with a hands-on learning experience that reinforced physics and mathematics concepts, utilizing technology tools to create functional artifacts. The project explored principles such as air resistance, gravity, acceleration, and terminal velocity—concepts that were largely unfamiliar to the students prior to the camp. While not all students mastered these ideas to the same extent, they demonstrated an understanding of fundamental concepts, such as distinguishing between acceleration and velocity and representing force vectors graphically. Acceleration, terminal velocity, and the variable nature of air resistance were particularly challenging, but the experiential learning approach facilitated meaningful assimilation of these concepts.

Students also applied mathematical principles to calculate dimensions, optimize designs, and interpret data. This interdisciplinary approach enabled the practical application of theoretical knowledge, enhancing both comprehension and retention. By engaging in the engineering design process, students were involved in problem-solving, iterative testing, and the refinement of their designs. This methodology encouraged them to connect various physics concepts and mathematical techniques, fostering a holistic understanding and the ability to transfer knowledge across domains.

The project promoted teamwork and collaboration as students worked in groups to share ideas and develop solutions. Additionally, it fostered critical thinking, as students analyzed test results and made data-driven adjustments to improve their designs. The structured nature of the EDP reinforced logical reasoning and systematic problem-solving, foundational skills for mastering physics and mathematics.

Beyond the context of a summer camp, this project could be adapted for European programs, after-school clubs, or incorporated into school curricula. It offers extensive opportunities for expansion, such as investigating additional factors influencing parachute performance, including payload mass, string configurations, wind effects, and alternative canopy materials or shapes. These variables could also serve as entry points for different levels of difficulty, making the project adaptable for students of various ages and knowledge levels. Individual components of the project could be integrated into the official middle school curriculum in schools equipped with the necessary resources and staffed by teachers proficient in programming and software applications (Theodoropoulou et al., 2023; Ampartzaki et al., 2022).

In the context of the International Baccalaureate (IB) Middle Years Program (MYP), “Design” plays a pivotal role in both formative and summative assessments, following the Design Cycle as a core methodology. While this framework benefits IB students, those outside such programs can also derive value from similar projects, enabling them to develop practical solutions to real-world problems.

This study highlights the efficacy of integrating hands-on projects with the engineering design process as a means of teaching physics and mathematics. By engaging students in real-world challenges, this approach fosters deeper learning, critical thinking, and the practical application of theoretical concepts. Ultimately, such projects not only enhance students’ understanding of complex ideas but also stimulate creativity and problem-solving abilities, preparing them for future endeavors in STEM disciplines.

## References

- Abd-El-Khalick, F., Waters, M., & Le A. (2008). Representations of Nature of Science in High School Chemistry Textbooks over the Past Four Decades, *Journal of Research in Science Teaching*, 45(7), 835-855.
- Ali, M., & Tse, A. W. (2023). Research Trends and Issues of Engineering Design Process for STEM Education in K-12: A Bibliometric Analysis, *International Journal of Education in Mathematics, Science and Technology*, 11(3), 695-727. <https://doi.org/10.46328/ijemst.2794>
- Ampartzaki, M., Kalogiannakis, M., Papadakis, S., & Giannakou, V. (2022). Perceptions about STEM and the arts: Teachers’, parents’ professionals’ and artists’ understandings about the role of arts in STEM education. In S. Papadakis, & M. Kalogiannakis (Eds.), *STEM, robotics, mobile apps in early childhood and primary education. Lecture notes in educational technology* (pp. 601-624). Singapore: Springer. [https://doi.org/10.1007/978-981-19-0568-1\\_25](https://doi.org/10.1007/978-981-19-0568-1_25)
- Anderson, J. (2020). The STEM education phenomenon and its impact on school curriculum. *Curriculum Perspectives*, 40, 217-223. <https://doi.org/10.1007/s41297-020-00107-3>
- Antink-Meyer, A., & Brown, R. A. (2019). Nature of Engineering Knowledge. *Science & Education*, 28, 539-559. <https://doi.org/10.1007/s11191-019-00038-0>
- Arik, M., & Topcu, M. S. (2023). Development and Implementation of engineering-based aircraft unit: middle school students’ engineering design process skills. *International Journal of Technology and Design Education*, 34, 603-628. <https://doi.org/10.1007/s10798-023-09829-7>
- Assante, D., Cennamo, G. M., & Placidi, L. (2020). 3D printing in education: an European perspective. In: *IEEE Global Engineering Education Conference (EDUCON)*, 1133-1138.
- Atman, C. J., Adams, R. S., Cardella, M. E., Turns, J., Mosborg, S., & Saleem, J. (2007). Engineering design processes: A comparison of students and expert practitioners. *Journal of Engineering Education*, 96(4), 359-379
- Barak, M., Ginzburg, T., & Erduran, S. (2022). Nature of Engineering. *Science & Education*, 33, 679-697. <https://doi.org/10.1007/s11191-022-00402-7>
- Bell, R. (2008). *Teaching the Nature of Science Through Process Skills: Activities for Grades 3-8*. Allyn & Bacon.
- Bybee, R. (2011). Scientific and Engineering Practices in K-12 Classrooms: Understanding A Framework for K-12 Science Education. *Science and Children*, 78(4).
- Çelik, A., & Özdemir, S. (2020). Tinkering learning in classroom: an instructional rubric for evaluating 3D printed prototype performance. *International Journal of Technology and Design Education*, 30, 459-478. <https://doi.org/10.1007/s10798-019-09512-w>
- Cunningham, C. M., & Carlsen, W. S. (2014). Teaching engineering practices. *Journal of Science Teacher Education*,

25(2), 197-210

- Dickson, B., Weber, J., Kotsopoulos, D. et al. (2021). The role of productive failure in 3D printing in a middle school setting. *International Journal of Technology and Design Education*, 31, 489-502. <https://doi.org/10.1007/s10798-020-09568-z>
- English, L. (2022). Fifth-grade Students' Quantitative Modeling in a STEM Investigation, *Journal for STEM Education Research*, 5, 134-162, <https://doi.org/10.1007/s41979-022-00066-6>
- English, L., & King, D. (2015). STEM learning through engineering design: fourth-grade students' investigations in aerospace. *International Journal of STEM Education*, 2(14), <https://doi.org/10.1186/s40594-015-0027-7>
- Faber, J. M., Grzech, L. G., Mahmoud, M. M., & Becker, K. H. (2020), The Effect of Summer Engineering Camps on Students' Interest in STEM Paper presented at 2020 ASEE Virtual Annual Conference Content Access. <https://doi.org/10.18260/1-2--35309>
- Ferrarelli, P., & Iocchi, L. (2021). Learning Newtonian Physics through Programming Robot Experiments. *Technology Knowledge and Learning*, 26, 789-824. <https://doi.org/10.1007/s10758-021-09508-3>
- Grillenberger, M. (2023). Why and How to Teach Physical Computing: Research and Practice in Computer Science Education at Secondary Schools. In: Keane, T., Fluck, A.E. (Eds.), *Teaching Coding in K-12 Schools*. Springer, Cham. [https://doi.org/10.1007/978-3-031-21970-2\\_15](https://doi.org/10.1007/978-3-031-21970-2_15)
- Gluck, P. (2003). Air Resistance on Falling Balls and Balloons, *The Physics Teacher*, 41, 178, <https://doi.org/10.1119/1.1557510>
- Gossen, D., & Ivey, T. (2023). The Impact of In- and Out-of-School Learning Experiences in the Development of Students' STEM Self-Efficacies and Career Intentions. *Journal for STEM Education Research*, 6, 45-74. <https://doi.org/10.1007/s41979-023-00090-0>
- Hales, C., & Gooch, S. (2004). *Managing the Design Team*. In: *Managing Engineering Design*. Springer, London. [https://doi.org/10.1007/978-0-85729-394-7\\_5](https://doi.org/10.1007/978-0-85729-394-7_5)
- Han, J., Kelley, T., & Knowles, J. G. (2022). Building a sustainable model of integrated stem education: investigating secondary school STEM classes after an integrated STEM project. *International Journal of Technology and Design Education*, 33, 1499-1523. <https://doi.org/10.1007/s10798-022-09777-8>
- Herron, M. (1971). The nature of scientific inquiry. In J. J. Schwab and P. F. Brandwein (Eds.), *The teaching of science* (3-103). Cambridge, MA: Harvard University Press.
- Hynes, M., Portsmouth, M., Dare, E., Milto, E., Rogers, C., Hammer, D., & Carberry, A. (2011). Infusing engineering design into high school STEM courses. Retrieved from <https://files.eric.ed.gov/fulltext/ED537364.pdf>
- Januszewski, A., & Molenda, M. (2008). *Educational Technology: A Definition with Commentary*. Routledge, New York and London, p.12-14.
- Kelley, T. R., & Knowles, J. G. (2016). A conceptual framework for integrated STEM education. *International Journal of STEM Education*, 3(1). <https://doi.org/10.1186/s40594-016-0046-z>
- Kelley, T. R. (2011). Engineer's notebook-A design assessment tool. *Technology and Engineering Teacher*, 70(7), 30
- Kinchin, J. (2018). Using an Arduino in physics teaching for beginners. *Phys. Educ.*, 53, 063007
- Koumara, A., & Plakitsi, K. (2020b). The Degree that Nature of Scientific Knowledge Aspects are Included in the Science Classes of Greek High Schools. *World Journal of Education*, 10(5), 1-17, <https://doi.org/10.5430/wje.v10n5p1>
- Kroes, P. (2012). *Technical artefacts: Creations of mind and matter: A philosophy of engineering design*. Springer.
- Langbeheim, E. (2015). A project-based course on Newton's laws for talented junior high-school students. *Physics Education*, 50, 410
- Leavy, A., Hourigan, M., O'Dwyer, A., Carroll, C., Corry, E., & Hamilton, M. (2021). How slow is your parachute?, *Science & Children*, 58(6), 38-45.
- Lederman, J. S., Lederman, N. G., Bartos, S. A., Bartels, S. L., Antink- Meye, A., & Schwartz, R. S. (2014a), Meaningful Assessment of Learners' Understandings About Scientific Inquiry—The Views About Scientific Inquiry (VASI) Questionnaire, *Journal of Research in Science Teaching*, 51(1), 65-83. <https://doi.org/10.1002/tea.21125>

- Lederman, N. G., Antink, A., & Bartos, S. (2014b). Nature of Science, Scientific Inquiry and Socio-Scientific Issues Arising from Genetics: A Pathway to Developing a Scientific Literate Citizenry. *Science & Education*, 23(2), 285-302.
- Lin, K. Y., Wu, Y. T., Hsu, Y. T. et al. (2021). Effects of infusing the engineering design process into STEM project-based learning to develop preservice technology teachers' engineering design thinking. *International Journal of STEM Education*, 8(1). <https://doi.org/10.1186/s40594-020-00258-9>
- McComas, W. (2020). Nature of Science and Classroom Practice: A Review of the Literature with Implications for Effective NOS Instruction, In W. McComas (Ed.), *Nature of Science in Science Instruction: Rationales and Strategies*. Springer Nature, Switzerland. p. 67-111.
- Merayo, N., & Ayuso, A. (2023). Analysis of barriers, supports and gender gap in the choice of STEM studies in secondary education. *International Journal of Technology and Design Education*, 33, 1471-1498. <https://doi.org/10.1007/s10798-022-09776-9>
- Millar, V. (2020). Trends, Issues and Possibilities for an Interdisciplinary STEM Curriculum. *Science & Education*, 29, 929-948. <https://doi.org/10.1007/s11191-020-00144-4>
- NGSS Lead States. (2013). *Next generation science standards: For states, by states*. The National Academies Press.
- Novak, E. (2022). *3D Printing in Education*. Routledge. <https://doi.org/10.4324/9781138609877-REE81-1>
- Pearson, H. A., & Dubé, A. K. (2022). 3D printing as an educational technology: theoretical perspectives, learning outcomes, and recommendations for practice. *Education and Information Technologies*, 27, 3037-3064. <https://doi.org/10.1007/s10639-021-10733-7>
- Pleasant, J. (2023). Rethinking the Nature of Engineering: Attending to the Social Context of Engineering. *Science & Education*, 33, 1353-1370. <https://doi.org/10.1007/s11191-023-00445-4>
- Popovic, G., & Lederman, J. S. (2015). Implications of informal education experiences for mathematics teachers' ability to make Connections beyond the formal classroom. *School Science and Mathematics*, 115(3), 129 -140. <https://doi.org/10.1111/ssm.12114>
- Reinsfield, E. (2020). A future-focused approach to the technology education curriculum: the disparity between intent and practice. *International Journal of Technology and Design Education*, 30, 149-161. <https://doi.org/10.1007/s10798-019-09497-6ree>
- Roberts, T., Jackson, C., Mohr-Schroeder, M. J. et al. (2018). Students' perceptions of STEM learning after participating in a summer informal learning experience. *International Journal of STEM Education*, 35(5). <https://doi.org/10.1186/s40594-018-0133-4>
- Roehrig, G., Moore, T., Wang, H., & Park M. S. (2015). Is Adding the E Enough? Investigating the Impact of K-12 Engineering Standards on the Implementation of STEM Integration. *School Science and Mathematics*, 112(1), 31-44. <https://doi.org/10.1111/j.1949-8594.2011.00112.x>
- Roehrig, G., Dare, E., Ring-Whalen, E., & Wieselmann, J. (2021). Understanding coherence and integration in integrated STEM curriculum. *International Journal of STEM Education*, 8(2), <https://doi.org/10.1186/s40594-020-00259-8>
- Shahali, E. H., Halim, L., Rasul M. S., Osman, K., & Zulkifeli, M. A. (2017). STEM Learning through Engineering Design: Impact on Middle Secondary Students' Interest towards STEM. *Eurasia Journal of Mathematics, Science and Technology Education*, 13(5), 1189-1211, <https://doi.org/10.12973/eurasia.2017.00667a>
- Shahat, M. A., Al-Balushi, S. M., & Al-Amri, M. (2023), Measuring preservice science teachers' performance on engineering design process tasks: implications for fostering STEM education. *Arab Gulf Journal of Scientific Research*. <https://doi.org/10.1108/AGJSR-12-2022-0277>
- Sulaeman, N. F., Putra, P. W., Mineta, I., Hakamada, H., Takahashi, M., Ide, Y., & Kumano, Y. (2021). Exploring Student Engagement in STEM Education through the Engineering Design Process. *Jurnal Penelitian dan Pembelajaran IPA*, 7(1), 1-16. <http://dx.doi.org/10.30870/jppi.v7i1.10455>
- Teiermayer, A. (2019) Improving students' skills in physics and computer science using BBC Micro:bit. *Physics Education*, 54, 065021.
- Theodoropoulou, I., Lavidas, K., & Komis, V. (2023). Results and prospects from the utilization of Educational Robotics in Greek Schools. *Technology Knowledge Learning*, 28, 225-240.

<https://doi.org/10.1007/s10758-021-09555-w>

Thyssen, C., & Meier, M. (2023). 3D Printing as an element of teaching—perceptions and perspectives of teachers at German schools. *Frontiers in Education*, 8:1233337. <https://doi.org/10.3389/educ.2023.1233337>

Wahyuni, Pratiwi, N., & Farhan A. (2021). The application of BBC micro:bit for automatic door controller. AIP Conference Proceedings, 2310, 050012. <https://doi.org/10.1063/5.0037633>

Wind, S. A., Alemdar, M., Lingle, J. A. et al. (2019). Exploring student understanding of the engineering design process using distractor analysis. *International Journal of STEM Education*, 6(4). <https://doi.org/10.1186/s40594-018-0156-x>

Yesilyurt, E., Deniz, H., & Kaya, E. (2021). Exploring sources of engineering teaching self-efficacy for pre-service elementary teachers. *International Journal of STEM Education*, 42(8). <https://doi.org/10.1186/s40594-021-00299-8>

Zhou, D., Gomez, R., Wright, N. et al. (2022). A design-led conceptual framework for developing school integrated STEM programs: the Australian context. *International Journal of Technology and Design Education*, 32, 383-411. <https://doi.org/10.1007/s10798-020-09619-5>

## Notes

Note 1. Resources for research <https://www.jpl.nasa.gov/edu/teach/activity/parachute-design/>

Note 2. Resources for research [https://www.esa.int/Education/CanSat/Design\\_your\\_parachute\\_A\\_Guide\\_to\\_Landing\\_Your\\_CanSat\\_Safely\\_Teach\\_with\\_Space\\_T10](https://www.esa.int/Education/CanSat/Design_your_parachute_A_Guide_to_Landing_Your_CanSat_Safely_Teach_with_Space_T10) and Playing with Parachutes - TryEngineering.org Powered by IEEE

Note 3. Resources for research <https://cansat.esa.int/>

Note 4. Resources for research <https://www.msichicago.org/science-at-home/hands-on-science/egg-drop-challenge/> or [https://www.nasa.gov/pdf/556927main\\_Adv-RS\\_Egg\\_Drop.pdf](https://www.nasa.gov/pdf/556927main_Adv-RS_Egg_Drop.pdf)

Note 5. Taken from [https://www.engineeringtoolbox.com/air-density-specific-weight-d\\_600.html](https://www.engineeringtoolbox.com/air-density-specific-weight-d_600.html) for 25oC

Note 6. Hexagon area calculation with 12 right triangles.

## Appendix 1: Quiz on physics concepts

Answer the following questions the best you can

1.
  - a) A dog can run very fast. Is it an example of speed or acceleration?
  - b) Marathon runners start slowing down as they get tired. Is it an example of speed or acceleration?
  - c) What is the speed of a rocket that travels 9.000 m in 12 sec?
  
2. What best describes what the acceleration of gravity is?
  - i. The speed at which an object moves due to gravity.
  - ii. The force that pulls objects toward the Earth.
  - iii. The rate at which an object's velocity changes due to gravity.
  - iv. The distance an object falls in a certain amount of time.

Explain your thoughts

3.
  - a) Draw the weight and the air resistance in the parachute below (only vectors).





b) Can you draw the weight and the air resistance in the three points of a parachute fall? Draw the vectors according to their values.

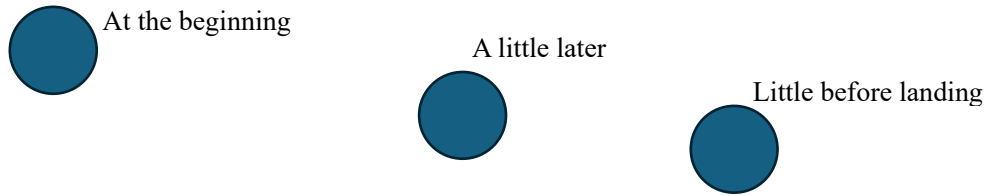

c) What do you know about the speed of the parachute as it touches the ground? Do you know if it has a special name?

4. Why one of the vehicles below is faster than the other? What is different in them, regarding acceleration and speed? Explain your answer



5. Solve the free fall equation  $h = \frac{1}{2}gt^2$  for time.

6. Take a careful look at the graph below. They illustrate the average monthly temperatures in three big cities: Paris, Dubai and Sydney. Can you understand which line represents each city? Explain your answer.

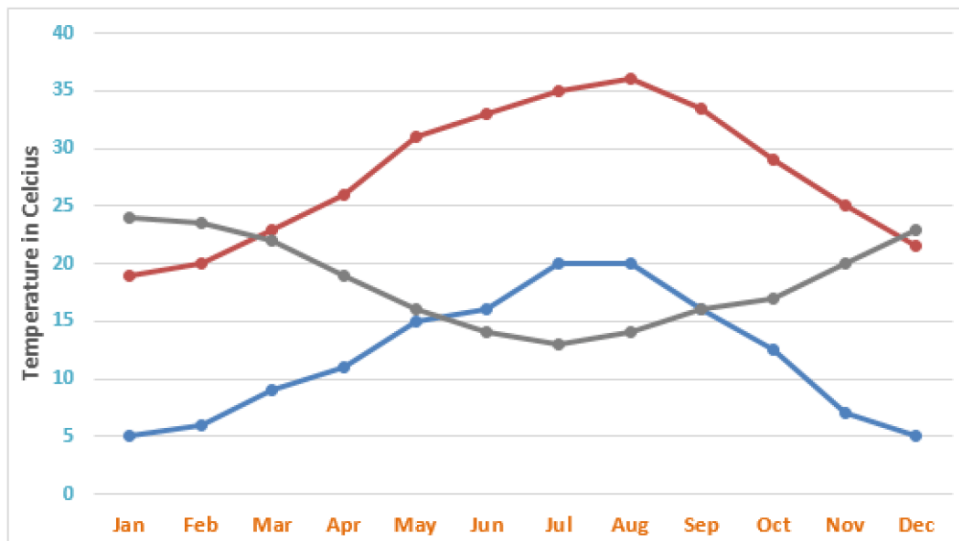

**Acknowledgments**

Not Applicable

**Authors contributions**

Dr. Anna Koumara and Prof. Hariton M. Polatoglou designed the basic stages of the research and the research questions. Dr Anna Koumara and Mr Michael Bakaloglou designed and implemented the lessons. Mr Michalis Bakaloglou worked in the technical part of the project. Dr Anna Koumara analyzed the data and wrote the drafts of

the paper. Finally, Prof. Hariton Polatoglou reviewed the paper.

**Funding**

Not Applicable.

**Competing interests**

The authors declare that they have no known competing financial interests or personal relationships that could have appeared to influence the work reported in this paper.

**Informed consent**

Obtained.

**Ethics approval**

The Publication Ethics Committee of the Sciedu Press.

The journal's policies adhere to the Core Practices established by the Committee on Publication Ethics (COPE).

**Provenance and peer review**

Not commissioned; externally double-blind peer reviewed.

**Data availability statement**

The data that support the findings of this study are available on request from the corresponding author. The data are not publicly available due to privacy or ethical restrictions.

**Data sharing statement**

No additional data are available.

**Open access**

This is an open-access article distributed under the terms and conditions of the Creative Commons Attribution license (<http://creativecommons.org/licenses/by/4.0/>).

**Copyrights**

Copyright for this article is retained by the author(s), with first publication rights granted to the journal.